



# MONITORED DOOR STATUS STANDARD MAGNETIC LOCK (1200LB)

**MAGNETIC LOCK**

Fire tested range of maglocks and brackets from a market leader in access control.

**FIRE TESTED** to  
BSEN1634-1-2014 & BS476:Part22:1987  
(30, 60, 90 & 120 min timber door-sets)



**ML1200-MDS**

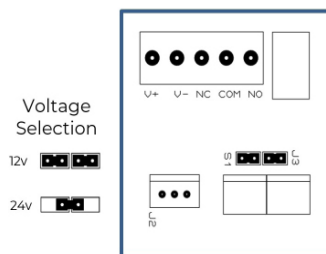
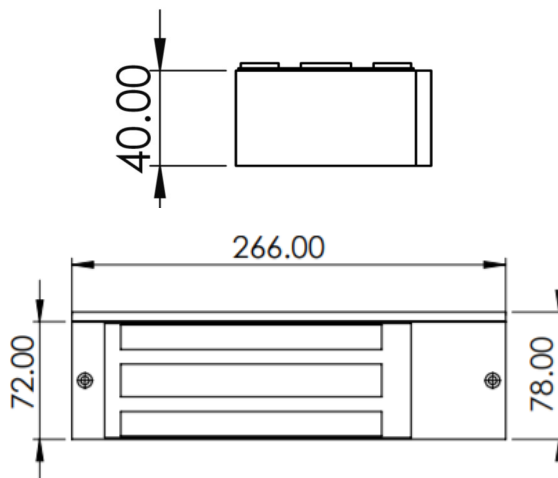

SPECIFICATION	FEATURES	OTHER PRODUCTS
---------------	----------	----------------

- ML1200-MDS**
- Aluminium housing
  - 12/24 VDC @600/300mA
  - 545kg (1200lb) holding force
  - Built in surge protection
  - Surface mount
  - Fail safe operation (power to lock)
  - +/- 15% voltage tolerance
  - 10° to +50° operating temperature
  - Push off release pin on armature
- 
- Monitored (Lock Monitoring)
  - Voltage free relay contacts
  - Door Status Monitoring

(Lock monitoring checks maglock is reporting itself as locked. Door status monitoring has a contact that works independently from the maglock, and shows if the door is open or closed)

- ML1200-MDS**
- Fire rated (30, 60, 80 & 120 min timber door set)
  - Standard magnet
  - Clean and compact design
  - No residual magnetism
  - Power LED indication on ML1200 (Red LED only)
  - Status LED indication on ML1200-M (Red to Green)
- Suitable Brackets/Housings:
- BK1200ZL (ZL bracket)
  - BK1200-F-L/AB (Architectural F/ZL)
- 
- BK1200L (L Bracket)
  - ADJ1200-L (Highly adjustable L)
  - AH1200 (Required for Fire Doors)

INWARD  
OUTWARD



**DIMENSIONS**

- ML1200-MDS**
- 266x72x40 (mm) Maglock (LxWxD)
  - 185x60x15 (mm) Armature (LxWxD)
  - 4.27kg Boxed
  - 2.79kg Unboxed

**CONTENTS**

- ML1200-MDS**
- Standard magnet
  - Armature plate
  - 1200GB fixing kit
  - Instructions
  - Armature fixing template

